

# Circular Unit Skylights

## Double or Triple Dome Curb Mount Units

- Vinyl curb with a rolled aluminum retainer
- No weep holes – reduces condensation and increases thermal performance
- Tested to compliance with AAMA\WDMA\CSA\101\I.S.2\A440 as required by the International Building Code



### Standard Sizes

Custom sizes not available.

Model:	<b>CC2/CC3-36*</b>	<b>CC2/CC3-48*</b>	<b>CC2/CC3-60</b>	<b>CC2/CC3-72</b>	<b>CC2/CC3-82</b>	<b>CC2/CC3-94</b>
Outside Dimension of Curb:	34"	46"	57"	70"	80"	92"

\*Florida Product Approved for non-impact (FL14417-19) with a design pressure +/- 100 PSF.

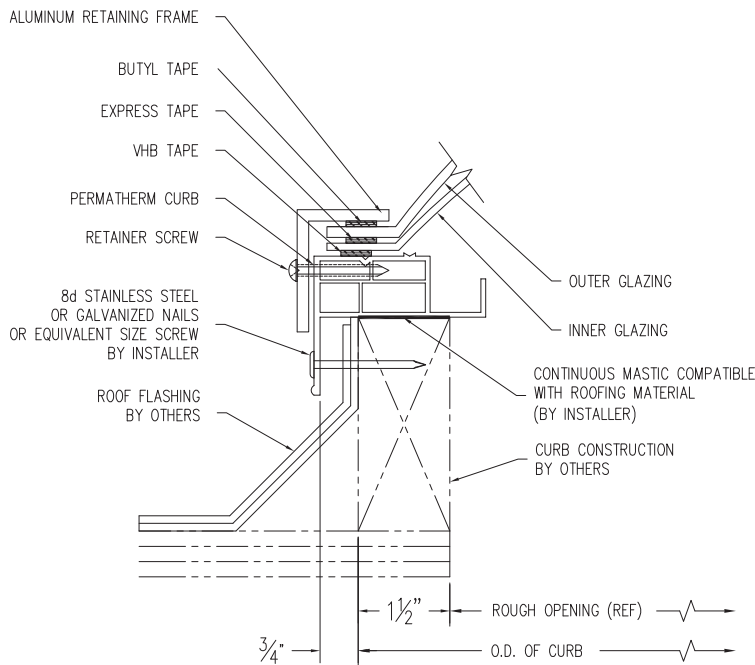

### Glazing:

- Outer: Clear, #2412 Bronze, or #2447 White
- Optional Middle: Clear or White
- Inner: Clear, White, or SatinIce\*

### Frame Finish:

- Frame finish is PVC, white interior and bronze exterior.
- Aluminum retainer frame.

### Retainer Finish:

- Mill (Standard)
- Anodized, Kynar 500, Baked Enamel
- Copper Clad

\* SatinIce glazing available in 60" or less.

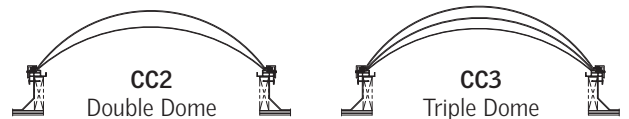

### SAFETY CONSIDERATIONS

Skylights pose an inherent risk of injury or death from fall throughs, and the safety of others is of the utmost importance to VELUX. VELUX recommends that the customer, building owner or manager use additional protection with the skylight such as an exterior or interior safety cage, to enhance long-term safety. The building owner or manager is responsible for providing fall protection around the skylight in accordance with OSHA regulations. VELUX also recommends that the building owner or manager restrict roof access only to personnel who have been cautioned as to the location of the skylights, and warned not to sit, step or walk on the skylights.