

# Tandem Unit Skylights

## Curb-mount fixed acrylic dome tandem unit system

Wasco's Tandem Unit System (SST) offers virtually unlimited design possibilities for a fully customized configuration.

The SST is a thermalized skylight system that allows domes or dome assemblies to be combined side by side in a single frame. Domes are separated by a structural purlin and are available single or double glazed with domed or pyramid shapes.

- Widths up to 8' and unlimited lengths
- For flat roof applications
- Curb mount – for use on minimum 1½" thick site-built or prefabricated curbs
- Extruded aluminum curb frame with integral condensation gutter and counter-flashing downward leg
- Maximum dome sizes of 9898 (95½" outside dimension of curb)
- Equal purlin spacing (equal dome sizes)
- Maximum unsupported purlin width of 5' @ 30 psf positive loading. Structural support required for 5' and above @ 30 psf positive loading, up to 8' widths
- Units ship assembled and glazed in sections up to 19' 6"

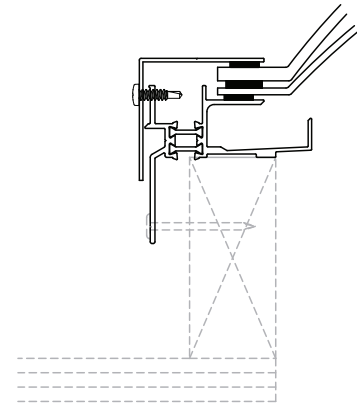
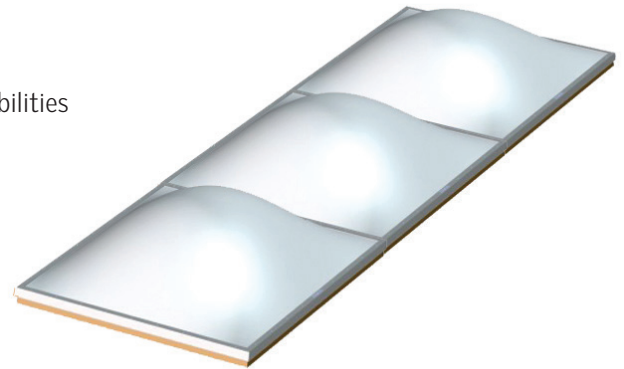

Sill Section

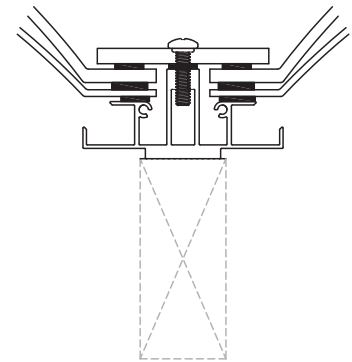

Rafter Section

### Glazing Options

Single Dome:

- Domed or pyramid shapes
- Glazing options - clear, bronze, or white

Double Dome:

- Domed or pyramid outer glazing shapes
- Outer glazing options - clear, bronze, white, or Satin Sky (limited sizes)
- Inner glazing options - clear or white

### Retainer Finish Options

- Mill (standard)
- Anodized, Kynar 500, baked enamel

### SAFETY CONSIDERATIONS



Skylights pose an inherent risk of injury or death from fall throughs, and the safety of others is of the utmost importance to VELUX. VELUX recommends that the customer, building owner or manager use additional protection with the skylight such as an exterior or interior safety cage, to enhance long-term safety. The building owner or manager is responsible for providing fall protection around the skylight in accordance with OSHA regulations. VELUX also recommends that the building owner or manager restrict roof access only to personnel who have been cautioned as to the location of the skylights, and warned not to sit, step or walk on the skylights.